



THE CORPORATION OF THE CITY OF BRAMPTON

*Repackaged -
See By-law 31-78*

BY-LAW

Number 321-77

A By-law to amend By-law Number 1827, as amended of the former Town of Brampton now in the City of Brampton.

The Council of the Corporation of the City of Brampton ENACTS that By-law Number 1827, as amended of the former Town of Brampton is hereby further amended, as follows:

1. Notwithstanding the provisions of Subsection 1 of Section 5, Residential Zone (R) of this By-law a building with gross floor area not exceeding One Thousand Five Hundred (1,500) square feet shall be permitted on lands located on the north side of Nelson Street West, west of Haggert Avenue North, as shown on Schedule A, attached hereto and subject to the following conditions:-
 - (a) the use of lands shall be restricted to the inside storage of goods as accessory to the existing commercial use of part of lands fronting on Haggert Avenue North.
 - (b) A minimum number of twelve (12) parking spaces shall be provided on the site as shown on Schedule 'A' attached hereto.
 - (c) Outside storage of goods is prohibited.
2. The regulations of height, rear yard and side yards as provided under Sub-section 3, Section 5 of the By-law shall apply to any structure or building to be located on the said lands.
3. Schedule 'A' attached hereto shall form part of the By-law.
4. This By-law shall take into effect upon approval by the Ontario Municipal Board.

READ a FIRST, SECOND and THIRD TIME and Passed in Open Council

this 19th day of December, 1977.

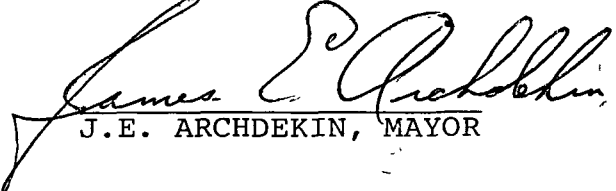
J.E. ARCHDEKIN, MAYOR

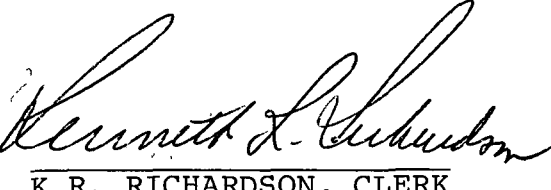

K.R. RICHARDSON, CLERK

PASSED December 19 1977

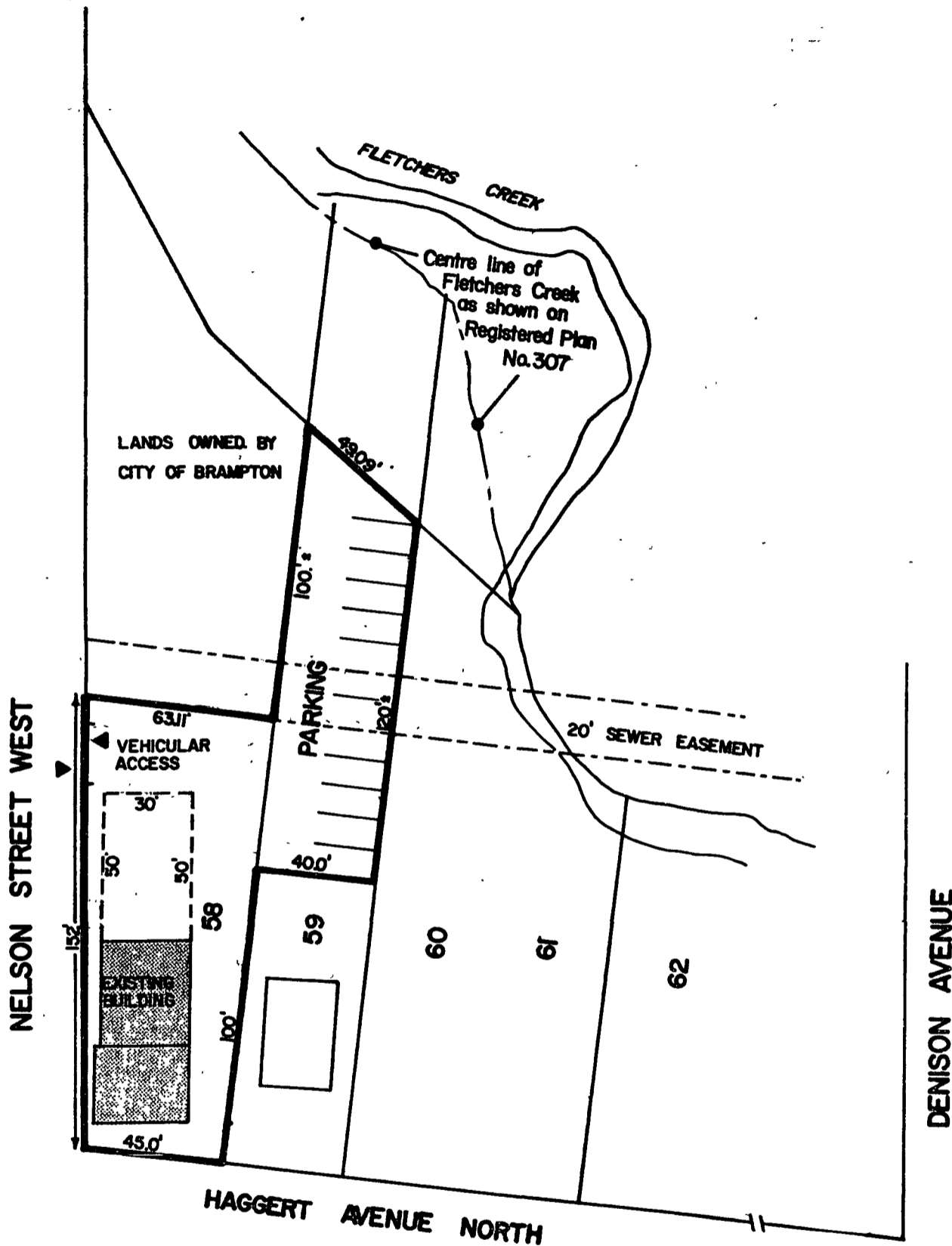

BY-LAW

No. 321-77

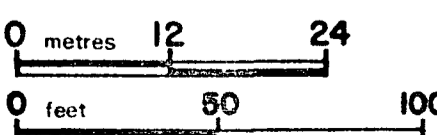

REGISTERED PLAN 307.

Application	SCHEDULE 'A' BY LAW No. 321-77		Drawn	DVC
			Date	JUNE 1977
Legend	Scale		File No.	
			Dwg. No.	A
			CITY OF BRAMPTON PLANNING DEPARTMENT	

BY-LAW 321-77 REPEALED BY BY-LAW 46-78